



AI JET

Pneumatic switches JET series

- Light with compact design
- Low operating force and high response time
- M5 threaded connections or push-in fitting tube Ø4
- Wide range of actuators and manual overrides for mounting panel (Original Univer)



TECHNICAL CHARACTERISTICS

Ambient temperature	-10 ÷ +90 °C
Fluid temperature	max +50 °C
Fluid	not dehumidified filtered air 50 µm, lubricated or not
Commutation system	poppet system
Ways/Positions	2/2 NC, 3/2 NC, 2/2 NO, 3/2 NO
Pressure	max 10 bar
Control	manual, mechanical
Return	mechanical spring
Connections	M5, tube Ø4
Nominal Ø	2,5 mm
Nominal flow rate (NI/min)	70 NI/min

CONSTRUCTIVE CHARACTERISTICS

Valve body	zamak
Seals	nitrile rubber
Spool	nickel-plated brass

OTHER VERSIONS AVAILABLE



Flow rate characteristics

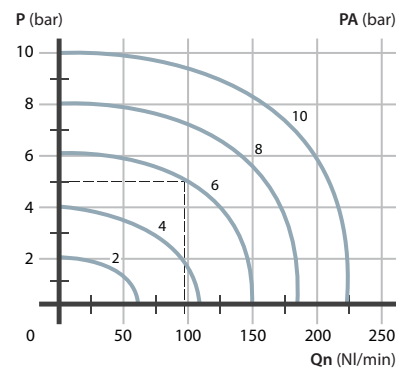

P = Working pressure
 PA = Supply pressure
 Qn = Flow rate

AI_JET Pneumatic switches



Ball-push - spring tube Ø4



	Symbol	Connection	Force (a) N	Weight Kg	Part no.
3/2 NC		tube Ø4	14	0,060	AI-9000
3/2 NO		tube Ø4	14	0,060	AI-9010
2/2 NC		tube Ø4	14	0,060	AI-9020
2/2 NO (b)		tube Ø4	14	0,060	AI-9030

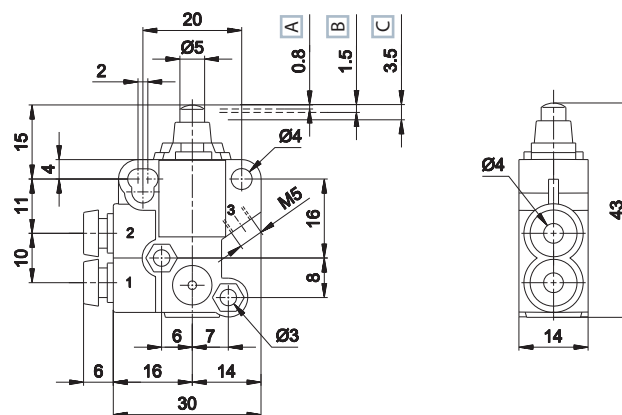

- A Pre-stroke
 - B Maximum opening
 - C Total stroke
- 1 = Supply port
 - 2 = Use
 - 3 = Exhaust

Ball-push - spring M5



	Symbol	Connection	Force (a) N	Weight Kg	Part no.
3/2 NC		M5	14	0,060	AI-9000M
3/2 NO		M5	14	0,060	AI-9010M
2/2 NC		M5	14	0,060	AI-9020M
2/2 NO (b)		M5	14	0,060	AI-9030M

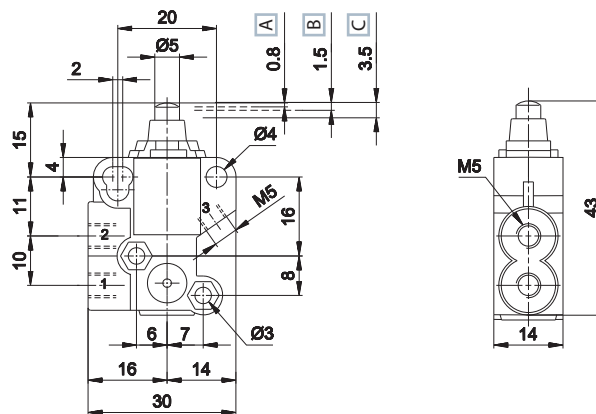

- A Pre-stroke
 - B Maximum opening
 - C Total stroke
- 1 = Supply port
 - 2 = Use
 - 3 = Exhaust

Roller lever - tube Ø4



	Symbol	Connection	Force (a) N	Weight Kg	Part no.
3/2 NC		tube Ø4	7	0,085	AI-9100
3/2 NO		tube Ø4	7	0,085	AI-9110
2/2 NC		tube Ø4	7	0,085	AI-9120
2/2 NO (b)		tube Ø4	7	0,085	AI-9130

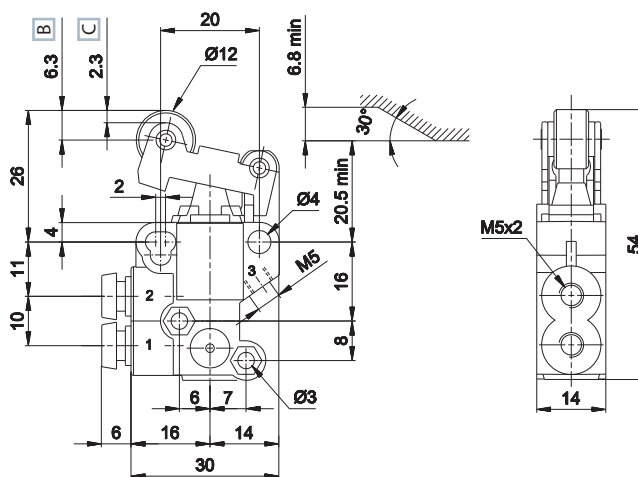

- B Maximum opening
 - C Total stroke
- 1 = Supply port
 - 2 = Use
 - 3 = Exhaust

(a) = at 6 bar (b) = upon request 2/2 NO version

AI_JET Pneumatic switches



Roller lever - spring M5



	Symbol	Connection	Force (a) N	Weight Kg	Part no.
3/2 NC		M5	7	0,085	AI-9100M
3/2 NO		M5	7	0,085	AI-9110M
2/2 NC		M5	7	0,085	AI-9120M
2/2 NO (b)		M5	7	0,085	AI-9130M

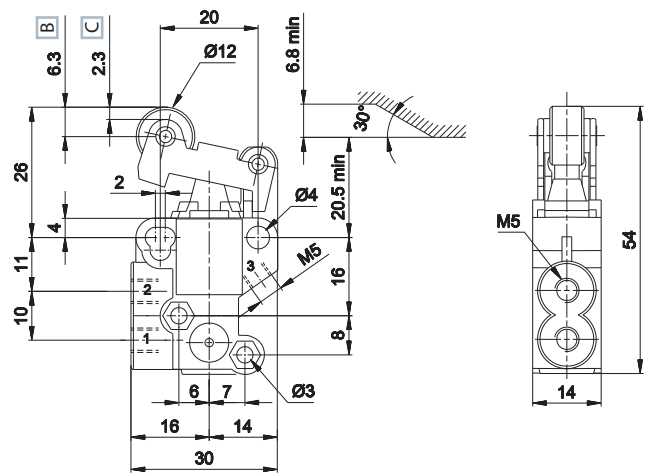

B Maximum opening
C Total stroke

1 = Supply port
2 = Use
3 = Exhaust

Uni-directional roller lever - spring tube Ø4



	Symbol	Connection	Force (a) N	Weight Kg	Part no.
3/2 NC		tube Ø4	4	0,085	AI-9200
3/2 NO		tube Ø4	4	0,085	AI-9210
2/2 NC		tube Ø4	4	0,085	AI-9220
2/2 NO (b)		tube Ø4	4	0,085	AI-9230

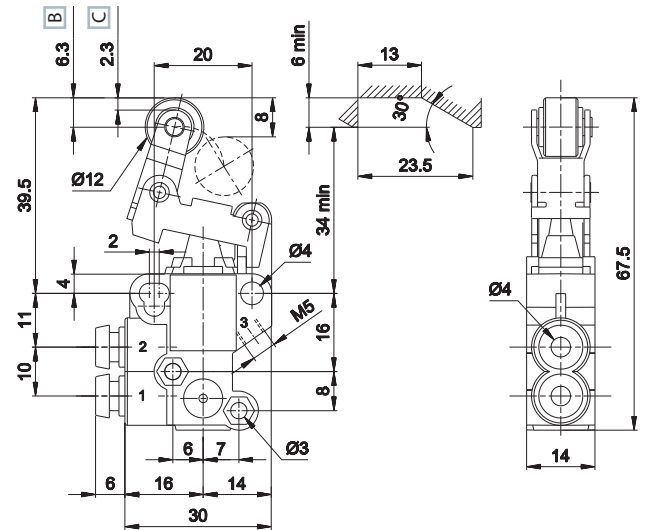

B Maximum opening
C Total stroke

1 = Supply port
2 = Use
3 = Exhaust

Uni-directional roller lever - spring M5



	Symbol	Connection	Force (a) N	Weight Kg	Part no.
3/2 NC		M5	4	0,085	AI-9200M
3/2 NO		M5	4	0,085	AI-9210M
2/2 NC		M5	4	0,085	AI-9220M
2/2 NO (b)		M5	4	0,085	AI-9230M

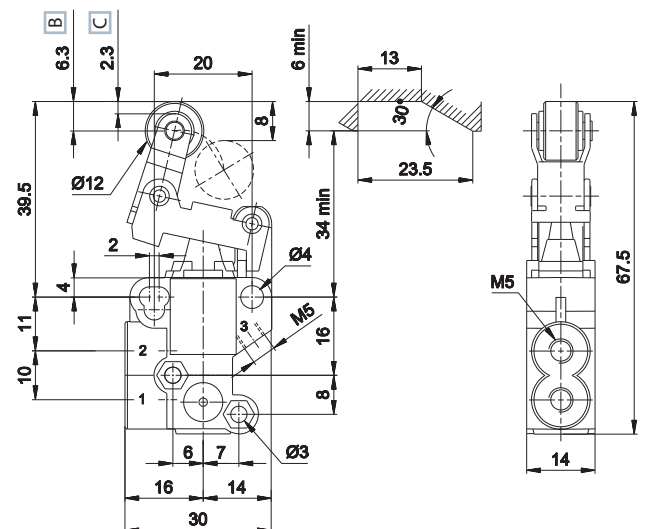

B Maximum opening
C Total stroke

1 = Supply port
2 = Use
3 = Exhaust

(a) = at 6 bar (b) = upon request 2/2 NO version

4
Poppet valves

AI_JET Pneumatic switches



Mechanical push button with screw mounting - spring tube Ø4



	Symbol	Connection	Force (a) N	Weight Kg	Part no.
3/2 NC		tube Ø4	14	0,082	AI-9300
3/2 NO		tube Ø4	14	0,082	AI-9310
2/2 NC		tube Ø4	14	0,082	AI-9320
2/2 NO (b)		tube Ø4	14	0,082	AI-9330

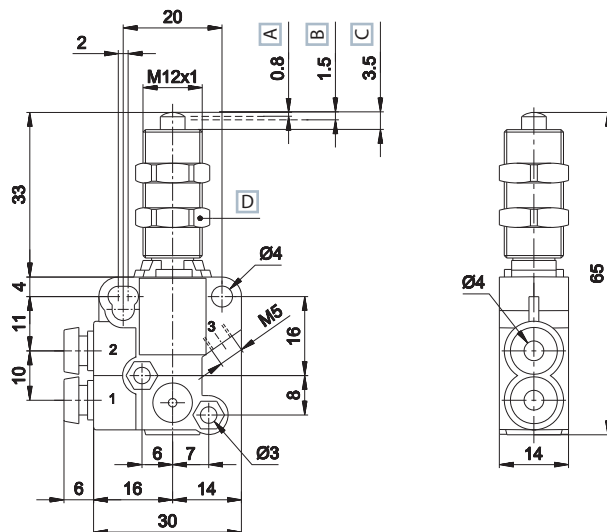

- A Pre-stroke
- B Maximum opening
- C Total stroke
- D Wrench 14
- 1 = Supply port
- 2 = Use
- 3 = Exhaust

Mechanical push button with screw mounting - spring M5



	Symbol	Connection	Force (a) N	Weight Kg	Part no.
3/2 NC		M5	14	0,082	AI-9300M
3/2 NO		M5	14	0,082	AI-9310M
2/2 NC		M5	14	0,082	AI-9320M
2/2 NO (b)		M5	14	0,082	AI-9330M

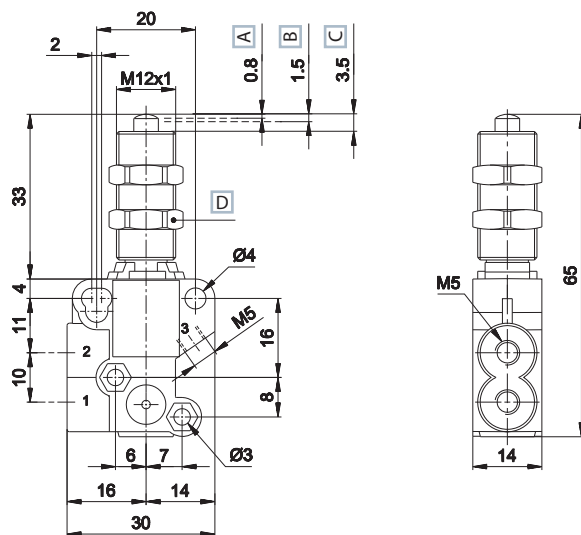

- A Pre-stroke
- B Maximum opening
- C Total stroke
- D Wrench 14
- 1 = Supply port
- 2 = Use
- 3 = Exhaust

(a) = at 6 bar (b) = upon request 2/2 NO version

AI_JET Pneumatic switches



Button - spring tube Ø4



	Symbol	Connection	Force (a) N	Weight Kg	Part no.
3/2 NC		tube Ø4	7	0,065	AI-9350
3/2 NO		tube Ø4	7	0,065	AI-9360
2/2 NC		tube Ø4	7	0,065	AI-9370
2/2 NO (b)		tube Ø4	7	0,065	AI-9380

Button yellow colour

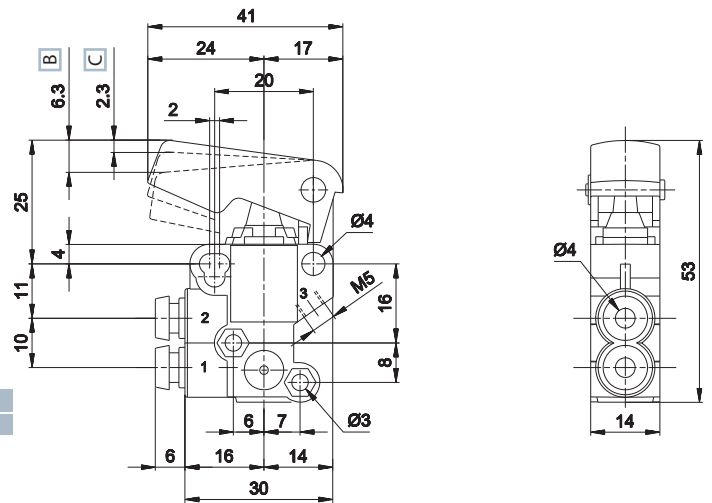

B Maximum opening
C Total stroke

1 = Supply port
2 = Use
3 = Exhaust

Button - spring M5



	Symbol	Connection	Force (a) N	Weight Kg	Part no.
3/2 NC		M5	7	0,065	AI-9350M
3/2 NO		M5	7	0,065	AI-9360M
2/2 NC		M5	7	0,065	AI-9370M
2/2 NO (b)		M5	7	0,065	AI-9380M

Button yellow colour

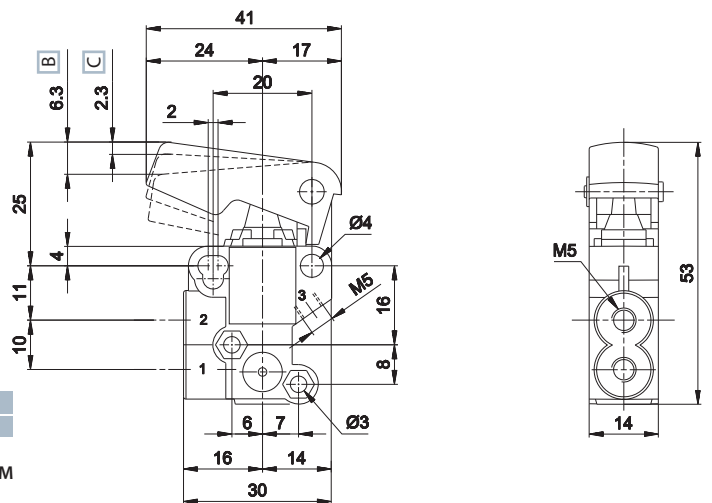

B Maximum opening
C Total stroke

1 = Supply port
2 = Use
3 = Exhaust

(a) = at 6 bar (b) = upon request 2/2 NO version

AI_JET Pneumatic switches



Mechanical push button for panel mounting - spring tube Ø4



	Symbol	Connection	Force (a) N	Weight Kg	Part no.
3/2 NC		tube Ø4	14	0,075	AI-9400
3/2 NO		tube Ø4	14	0,075	AI-9410
2/2 NC		tube Ø4	14	0,075	AI-9420
2/2 NO (b)		tube Ø4	14	0,075	AI-9430

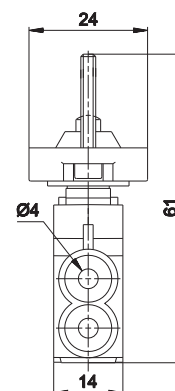
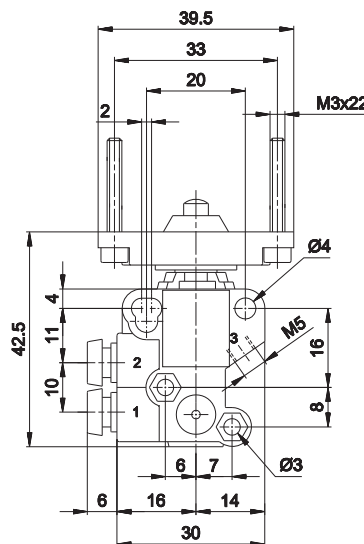

1 = Supply port
2 = Use
3 = Exhaust

Mechanical push button for panel mounting - spring M5



	Symbol	Connection	Force (a) N	Weight Kg	Part no.
3/2 NC		M5	14	0,075	AI-9400M
3/2 NO		M5	14	0,075	AI-9410M
2/2 NC		M5	14	0,075	AI-9420M
2/2 NO (b)		M5	14	0,075	AI-9430M

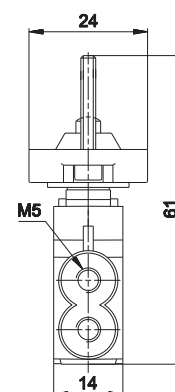
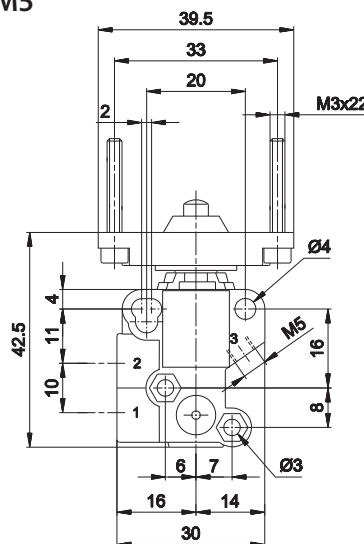

1 = Supply port
2 = Use
3 = Exhaust

MANUAL ACTUATORS

	Recessed button	<ul style="list-style-type: none"> BLACK AI-3511Q RED AI-3512Q GREEN AI-3513Q 		Rotating lever selector	<ul style="list-style-type: none"> BLACK AI-3522Q BLACK AI-3523Q
	Head button	<ul style="list-style-type: none"> RED AI-3514Q BLACK AI-3516Q RED AI-3514QD BLACK AI-3516QD 		Lever operator	<ul style="list-style-type: none"> BLACK AI-3524Q
	Button	<ul style="list-style-type: none"> GREEN AI-3515Q RED AI-3517Q BLACK AI-3519Q 		Omni-directional operator	<ul style="list-style-type: none"> BLACK AI-3525Q
	Rotating selector	<ul style="list-style-type: none"> BLACK AI-3520Q BLACK AI-3521Q 		Push-pull operator	<ul style="list-style-type: none"> BLACK AI-3526Q

(a) = at 6 bar (b) = upon request 2/2 NO version
For actuator dimensions refer to section "Accessories>Actuators"